

80-20501-40

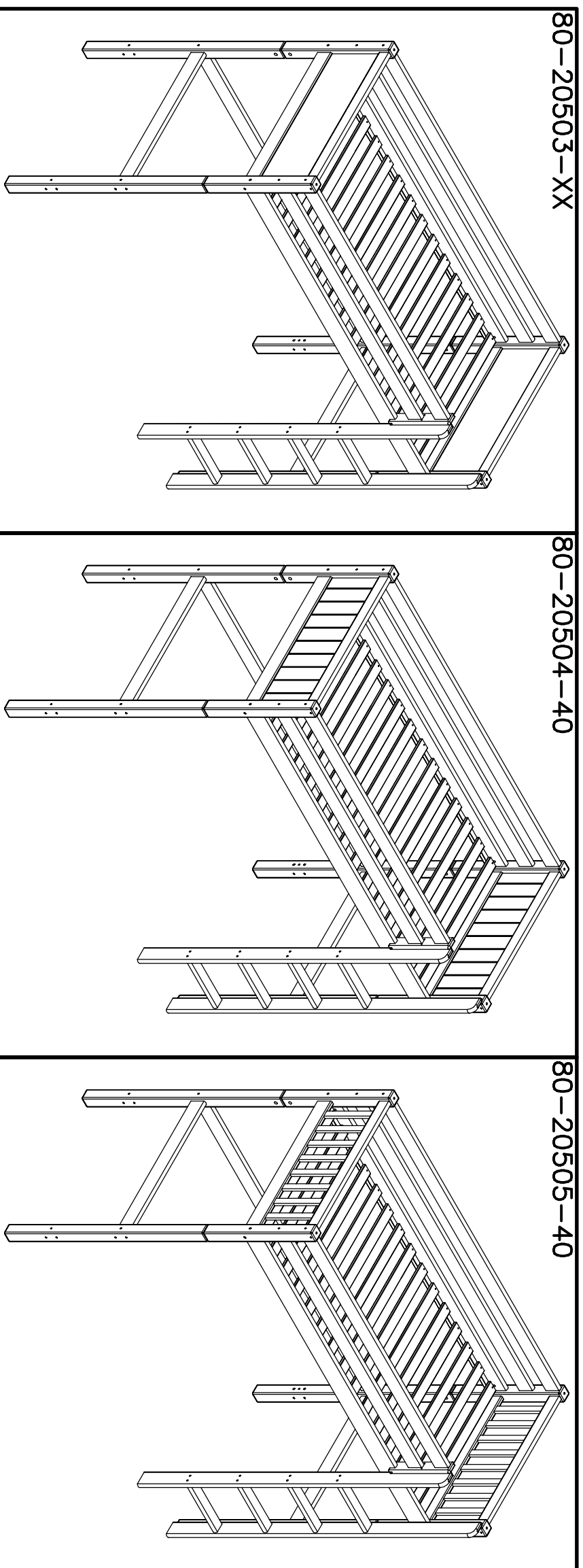

Before assembling this product, please ensure that all the components supplied comply with the list on this page. All Screw-type fittings can be tightened with this tool.

Avant de commencer l'assemblage, veuillez contrôler si tous les objets indiqués sont présents. Tous les vis peuvent être serrés par cet outil.

Bevor Sie mit dem Aufbau beginnen, kontrollieren Sie ob alle auf der Zeichnung angegebenen Teile vorhanden sind. Bitte verwenden Sie zur Montage einen Kreuzschraub-Ziher und den beiliegenden Innensechskantschlüssel.

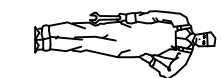
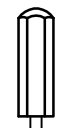

Ware-nr.
Part no.
Réf No

Stück.
Qty.
Qté.

Siehe Bild-nr.
See picture no.
Image no

Mass
Dim.
Dim.

12-02603182-40

4 stck/pcs.

12-02618331-40

2 stck/pcs.

12-02619676-40

3 stck/pcs.

12-06311863-40

2 stck/pcs.

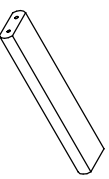

A

12-02603611-40

1 stck/pcs.

318x65x26

1833x89x26

1186x63x63

2 stck/pcs.

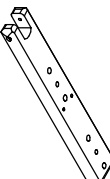

B

12-02608634-40

2 stck/pcs.

361x65x26

1833x89x26

1186x63x63

2 stck/pcs.



C

3930-10050 20 stck/pcs.

3909-70100

863x26x26

1571x89x26

1967x89x26

1186x63x63

3907-63022

4 stck/pcs.

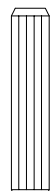

Z2

4007-014

2 stck/pcs.

3922-10028

4 stck/pcs.

3909-70060

4 stck/pcs.

3933-15028

4 stck/pcs.



Z3

4008-021

3922-10028

4 stck/pcs.

3909-70060

4 stck/pcs.

3933-15028

4 stck/pcs.



Z4

3922-10028

4 stck/pcs.

3909-70060

4 stck/pcs.

3933-15028

4 stck/pcs.

4 stck/pcs.



Z8

3922-10028

4 stck/pcs.

3909-70060

4 stck/pcs.

3933-15028

4 stck/pcs.

4 stck/pcs.



Z9

3922-10028

4 stck/pcs.

3909-70060

4 stck/pcs.

3933-15028

4 stck/pcs.

4 stck/pcs.



Z10

3922-10028

4 stck/pcs.

3909-70060

4 stck/pcs.

3933-15028

4 stck/pcs.

4 stck/pcs.



Z11

3922-10028

4 stck/pcs.

3909-70060

4 stck/pcs.

3933-15028

4 stck/pcs.

4 stck/pcs.



Z12

3922-10028

4 stck/pcs.

3909-70060

4 stck/pcs.

3933-15028

4 stck/pcs.

4 stck/pcs.



Z13

3922-10028

4 stck/pcs.

3909-70060

4 stck/pcs.

3933-15028

4 stck/pcs.

4 stck/pcs.

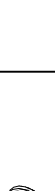

Z14

3922-10028

4 stck/pcs.

3909-70060

4 stck/pcs.

3933-15028

4 stck/pcs.

4 stck/pcs.



Z15

3922-10028

4 stck/pcs.

3909-70060

4 stck/pcs.

3933-15028

4 stck/pcs.

4 stck/pcs.



Z16

3922-10028

4 stck/pcs.

3909-70060

4 stck/pcs.

3933-15028

4 stck/pcs.

4 stck/pcs.



Z17

3922-10028

4 stck/pcs.

3909-70060

4 stck/pcs.

3933-15028

4 stck/pcs.

4 stck/pcs.



Z18

3922-10028

4 stck/pcs.

3909-70060

4 stck/pcs.

3933-15028

4 stck/pcs.

4 stck/pcs.

See assembly instruction in box no. 80-20101-40

Voir notice de montage dans la caisse no. 80-20101-40

Siehe Aufbauanleitung im karton no. 80-20101-40

Zie voor de montage-instructie pakketnr. 80-20101-40

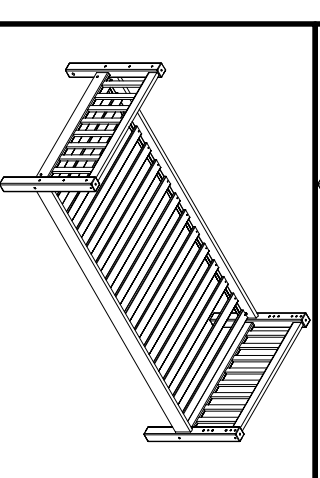
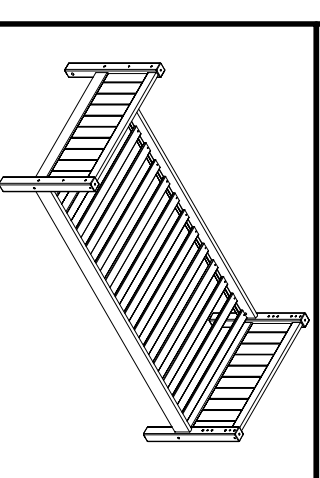
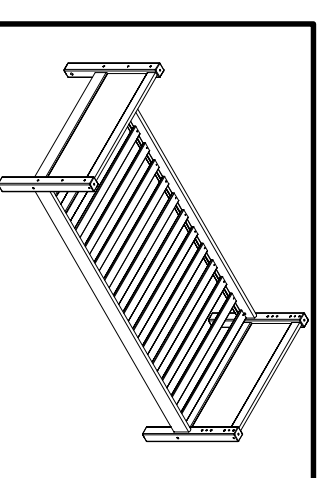

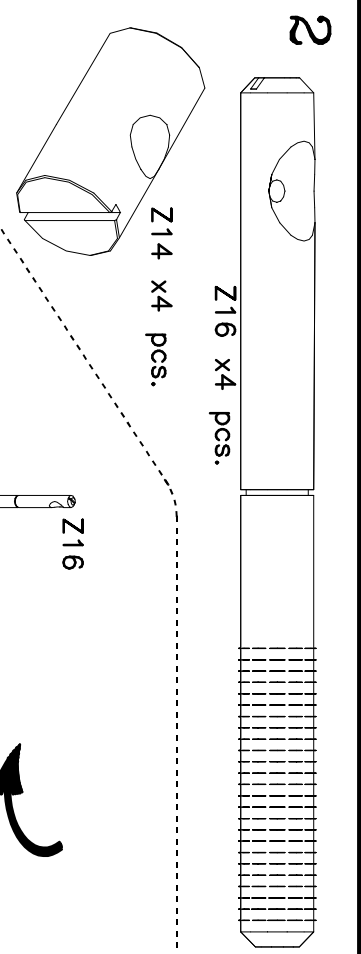
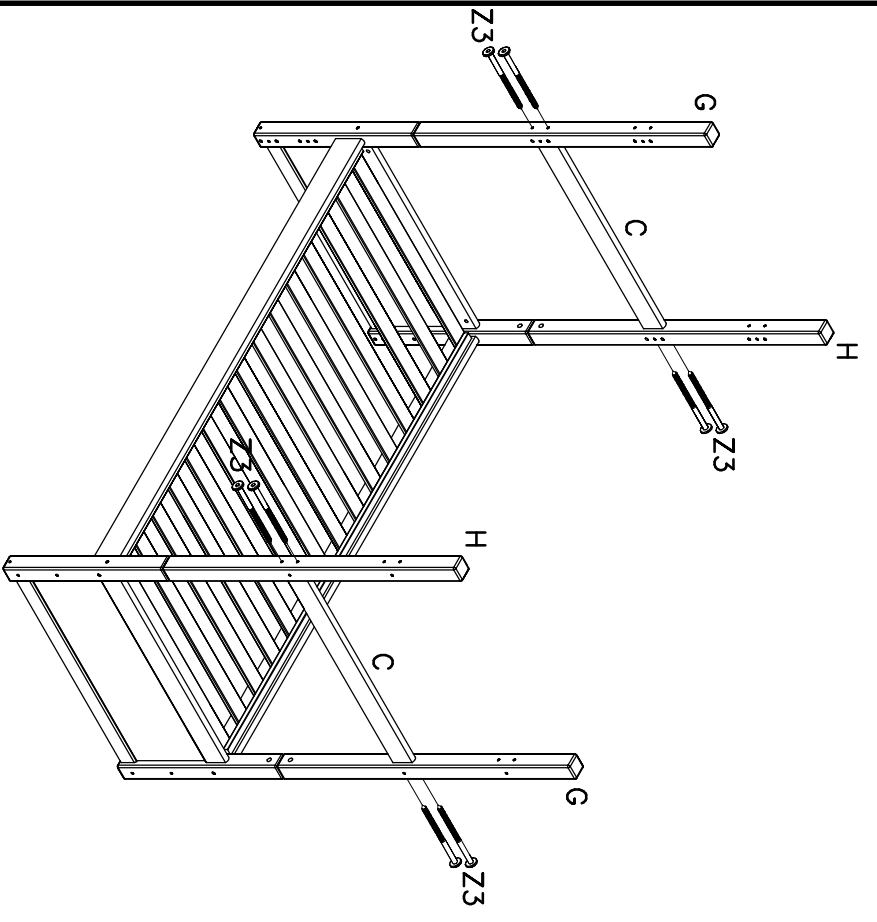
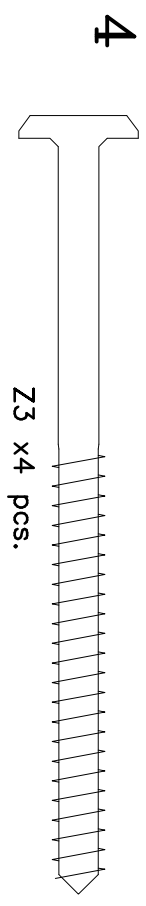
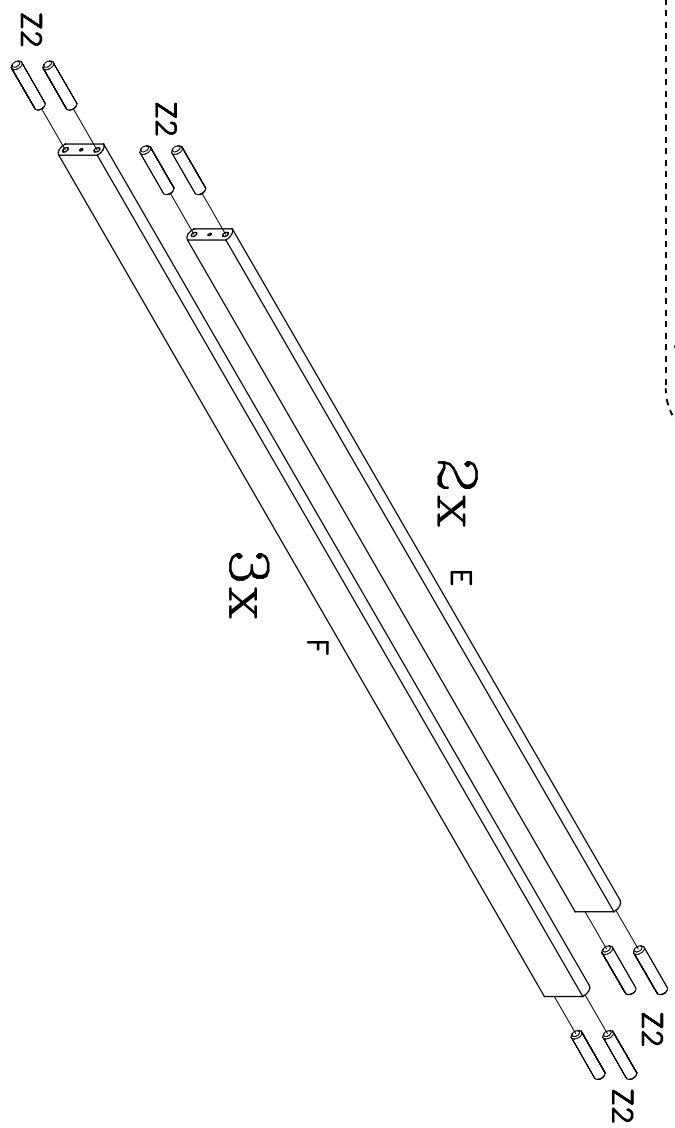
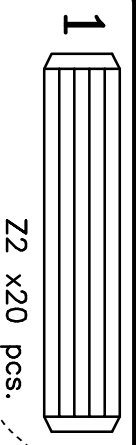

Screw the bolt Z16 into the leg, until the ring on the bolt is flush with the end of the leg.
 Schroef de bout Z16 in de poot, tot de ringmarkering op de bout gelijkvalt met de bovenzijde van de poot.
 Der Verbindungsbolzen Z16 wird eingeschraubt, bis der markierte Ring mit der Oberkante des Pfostens bündig ist.
 Visser le goujon dans le pied jusqu'à ce que l'anneau gravé soit à fleur avec le bois.

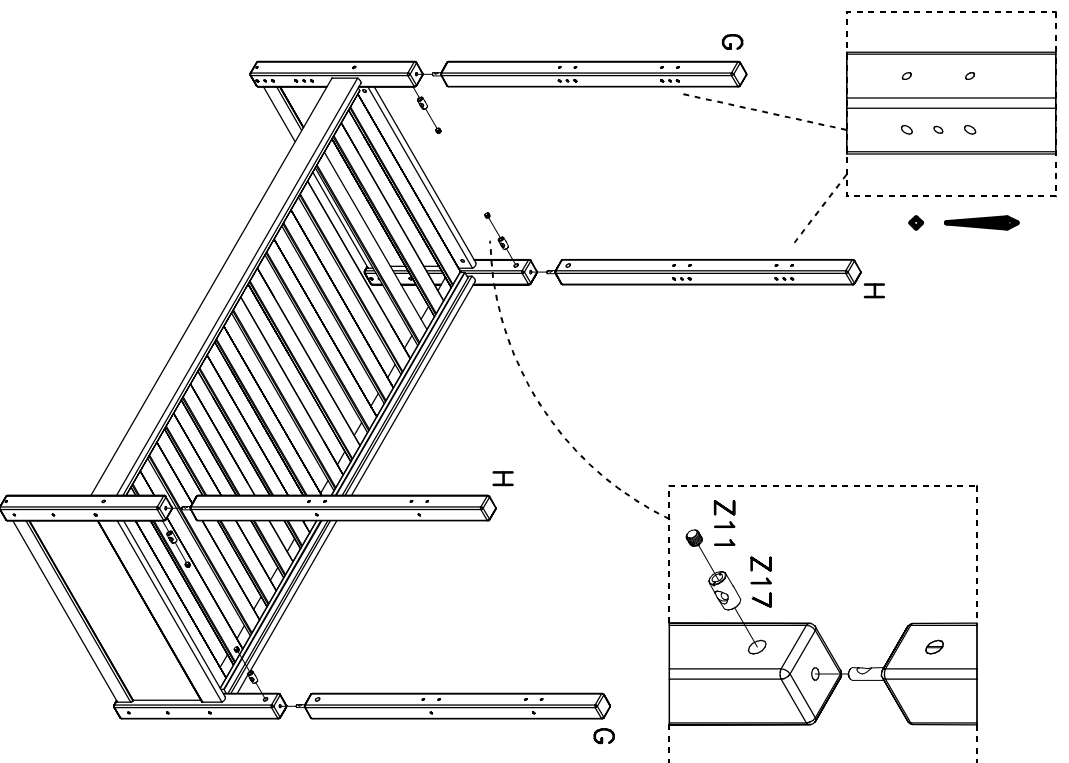
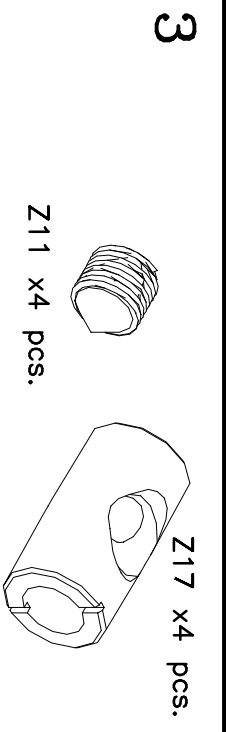
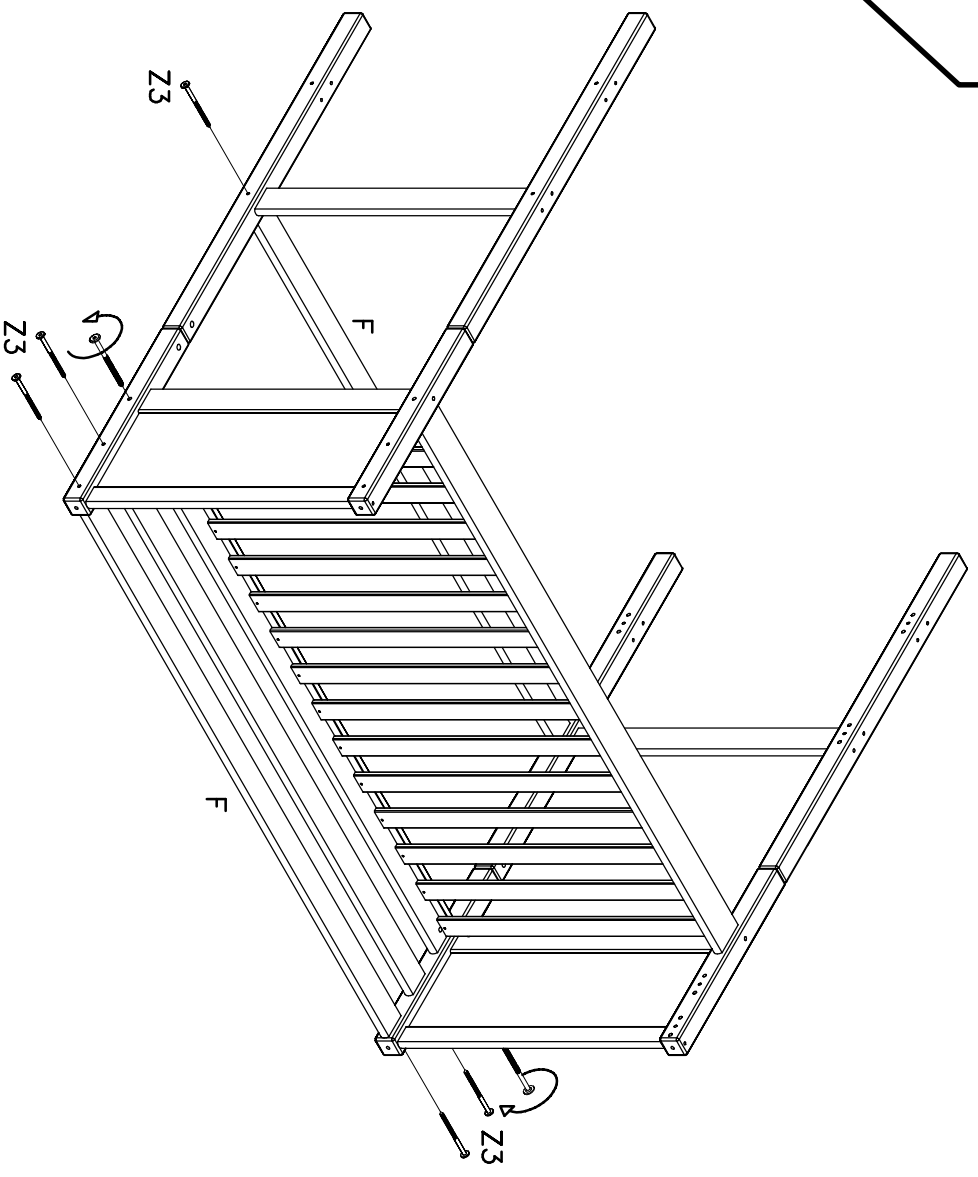
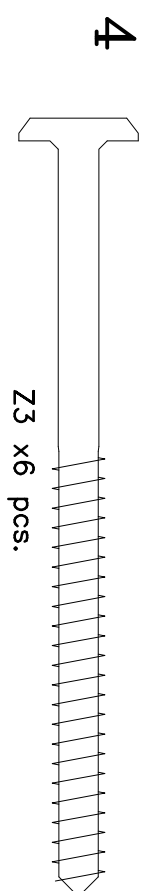
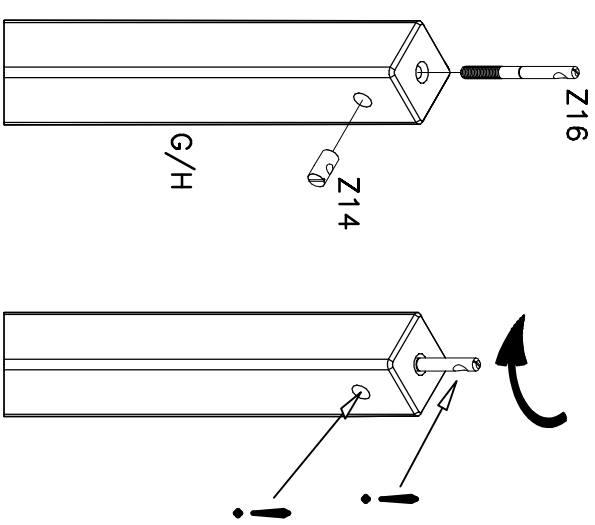

If the leg is loose after assembly, loosen the screw Z11 slightly, until the lower leg can be turned 1 time around clockwise. Then tighten the Z11 screw again.
 Indien de poot na montage niet vast genoeg zit, dient u schroef Z11 iets los te draaien, tot de onderste poot 1 keer rechtsom gedraaid kan worden. Daarna kunt u schroef Z11 weer vastschroeven.
 Wenn die Pfosten nicht fest genug angezogen sind, muss die Schraube Z11 leicht gelöst werden, bis der untere Pfosten 1 Mal rechts herum gedreht werden kann. Dann muss die Schraube Z11 wieder gespannt werden.
 Si les deux montants de pied ne sont pas suffisamment serrés, il convient de desserrer légèrement la vis Z11, jusqu'à pouvoir tourner la partie inférieure du pieds 1 fois dans le sens des aiguilles d'une montre. Ensuite resserrer la vis Z11.

6

Z3 x2 pcs.

Z15 x2 pcs.

Z4 x2 pcs.

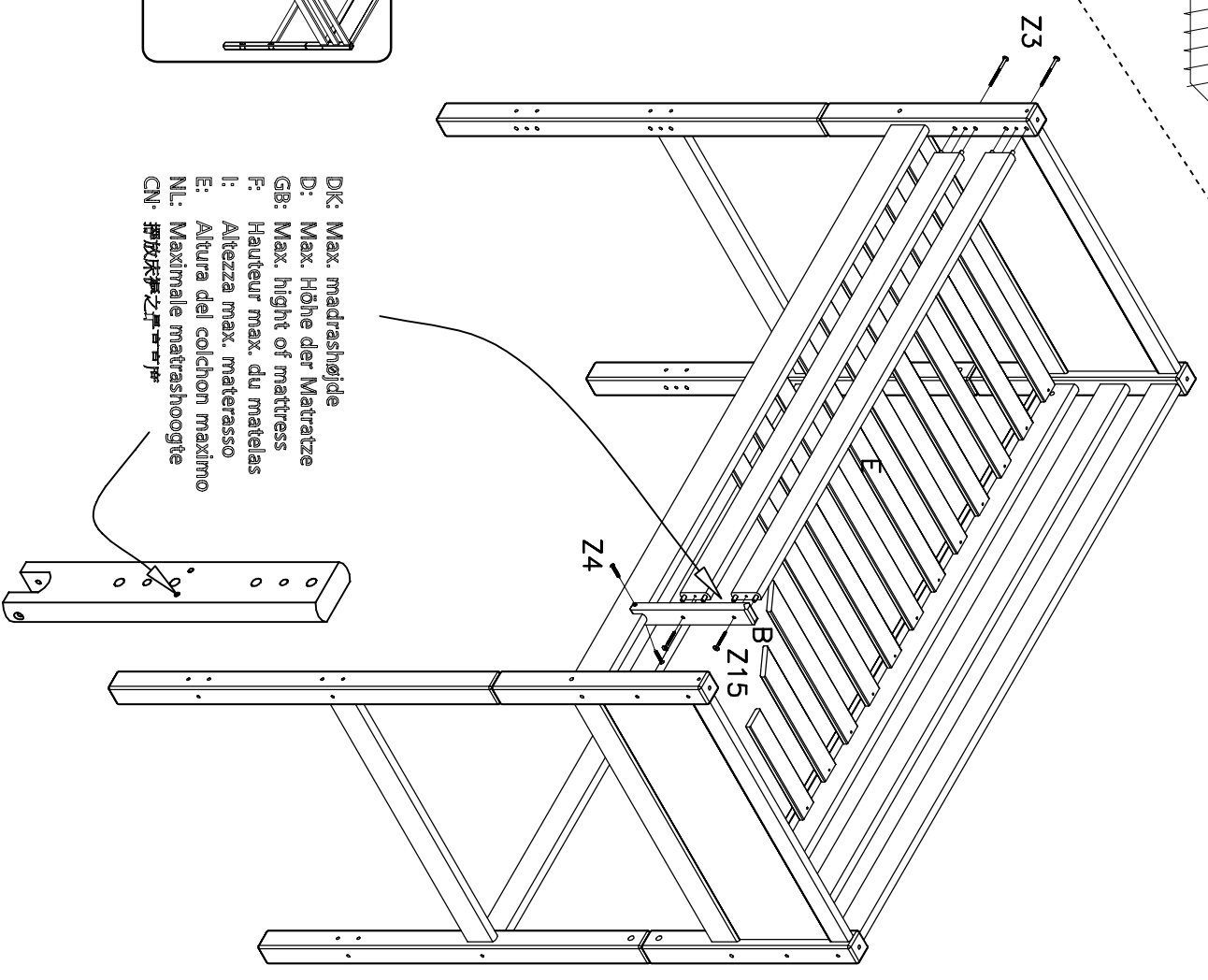
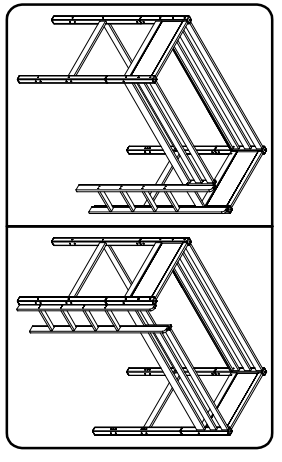

- DK: Max. madrashøjde
- D: Max. Höhe der Matratze
- GB: Max. hight of mattress
- F: Hauteur max. du matelas
- I: Altezza max. materasso
- E: Altura del colchon maximo
- NL: Maximale matrashoogte
- CN: 摺放床架之最大高度

7

Z15 x16 pcs.

Z4 x4 pcs.

Z10 x4 pcs.

Z13 x4 pcs.

Z12 x2 pcs.

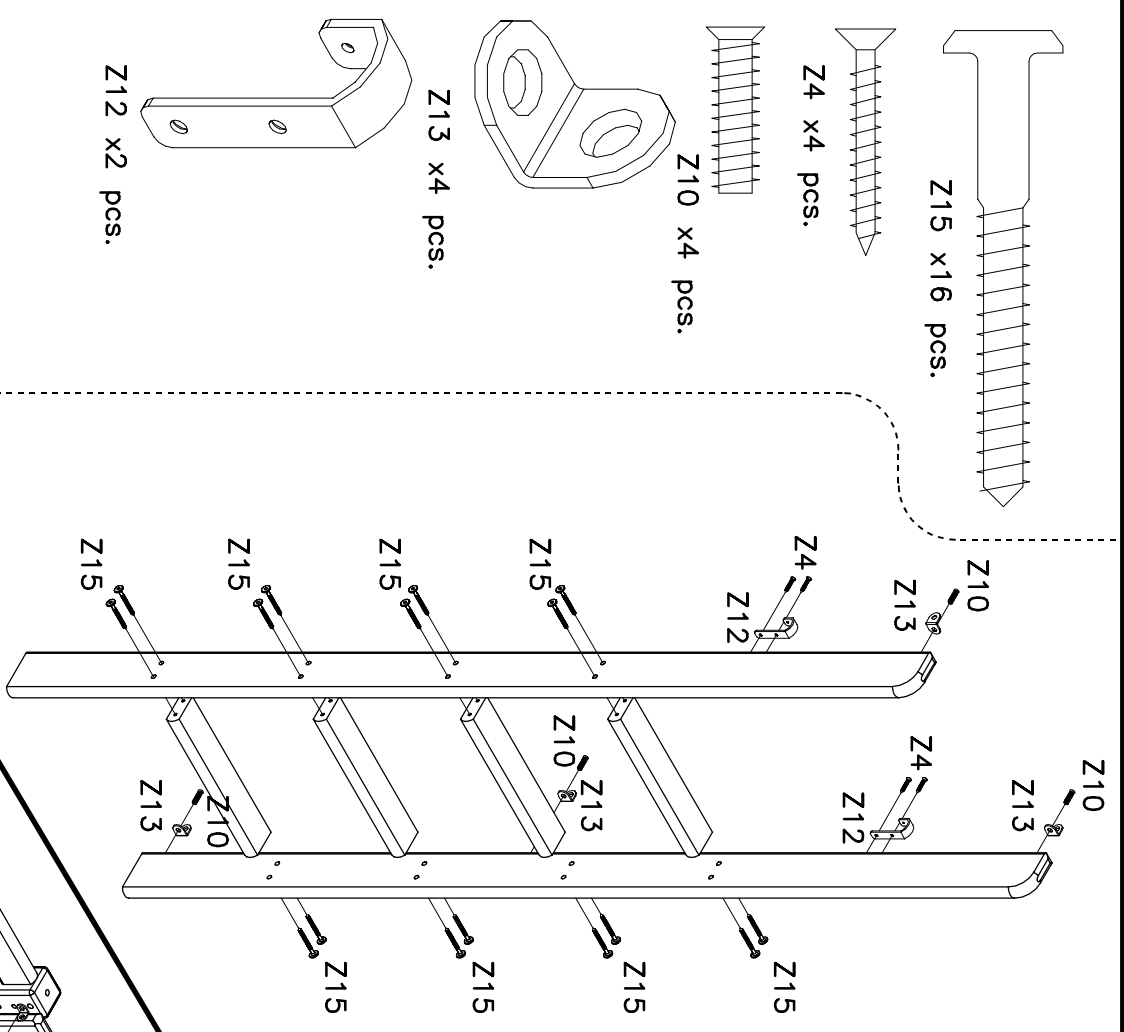

8

Z9 x4 pcs.

Z18 x2 pcs.

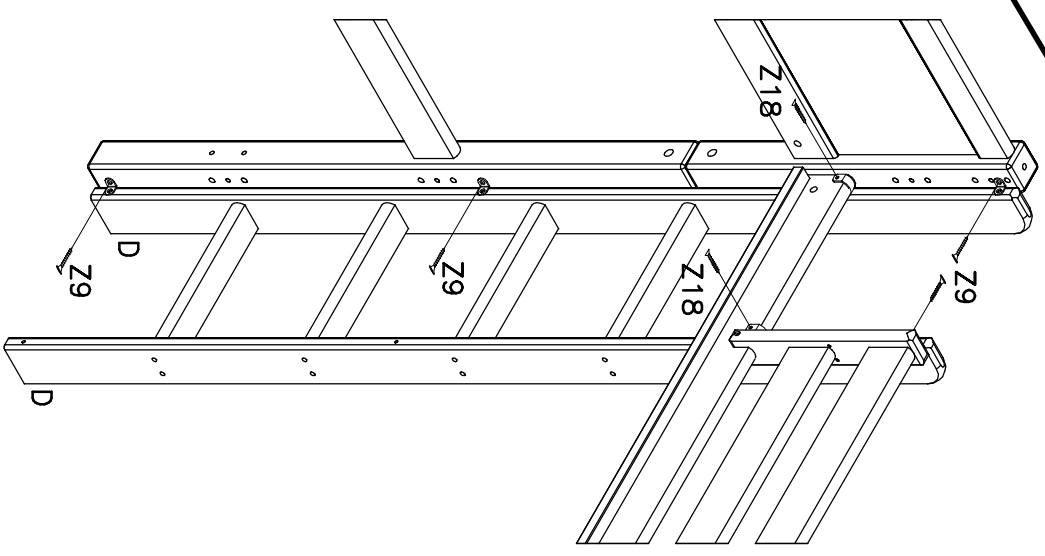

80-20601-40

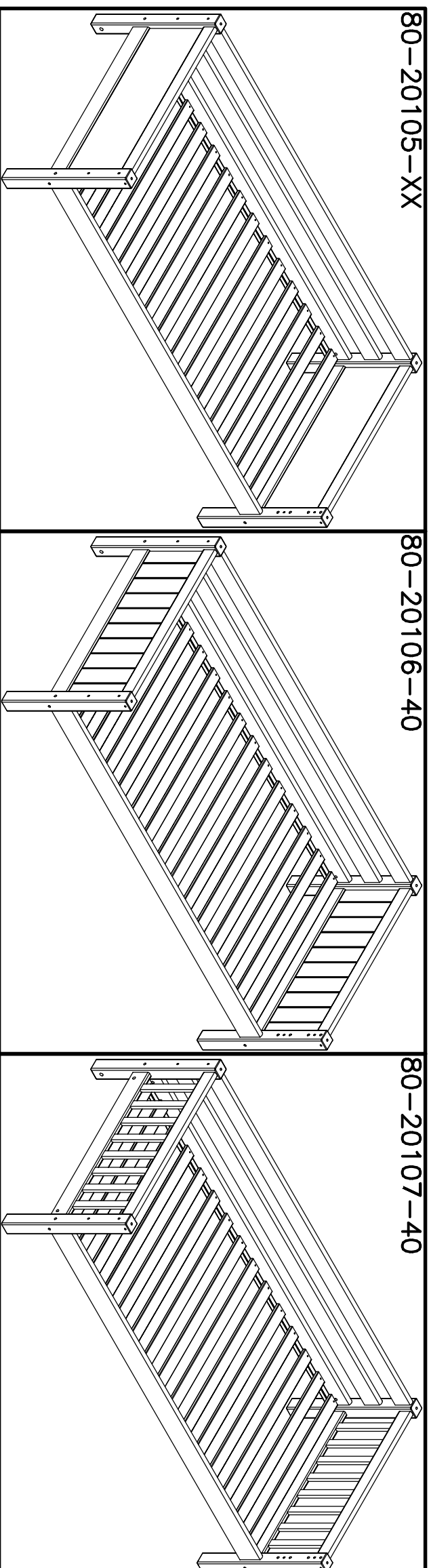

Before assembling this product, please ensure that all the components supplied comply with the list on this page. All Screw-type fittings can be tightened with this tool.



Avant de commencer l'assemblage, veuillez contrôler si tous les objets indiqués sont présents. Tous les vis peuvent être serrés par cet outil.

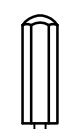

Bevor Sie mit dem Aufbau beginnen, kontrollieren Sie ob alle auf der Zeichnung angegebenen Teile vorhanden sind. Bitte verwenden Sie zur Montage einen Kreuzschraub-Ziher und den beiliegenden Innensechskantschlüssel.

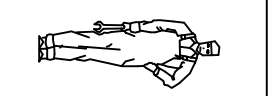

Ware-nr.
Part no.
Réf No

Siehe Bild-nr.
See picture no.
Image no

Stck.
Qty.
Qté.

Mass
Dim.
Dim.

12-02619676-40

2 stck/pcs.

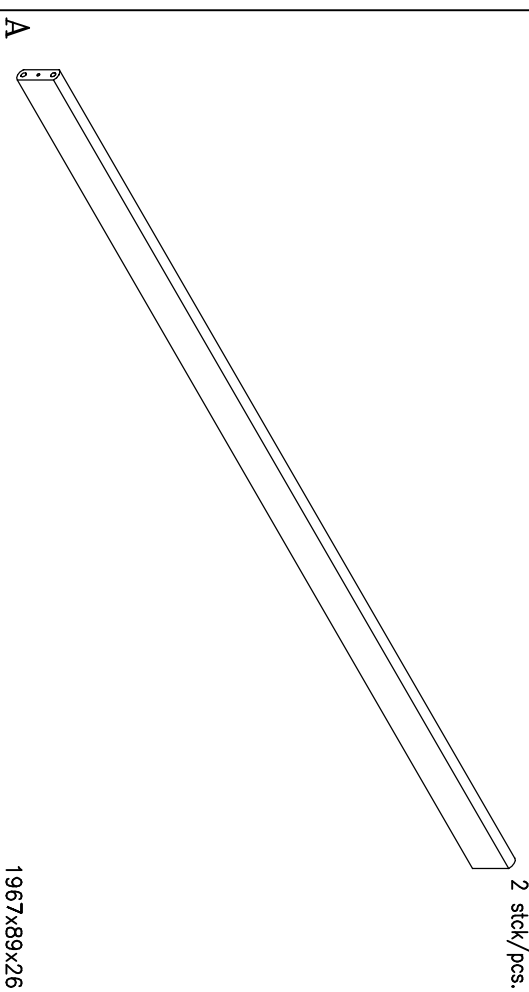

3930-10050 8 stck/pcs. 3909-70100

4 stck/pcs.

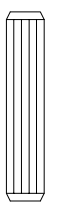

Z2 ø10x50 mm.



Z3 ø7x100 mm.

See assembly instruction in box no. 80-20101-40

Voir notice de montage dans la caisse no. 80-20101-40

Siehe Aufbauanleitung im karton no. 80-20101-40

Zie voor de montage-instructie pakketnr. 80-20101-40

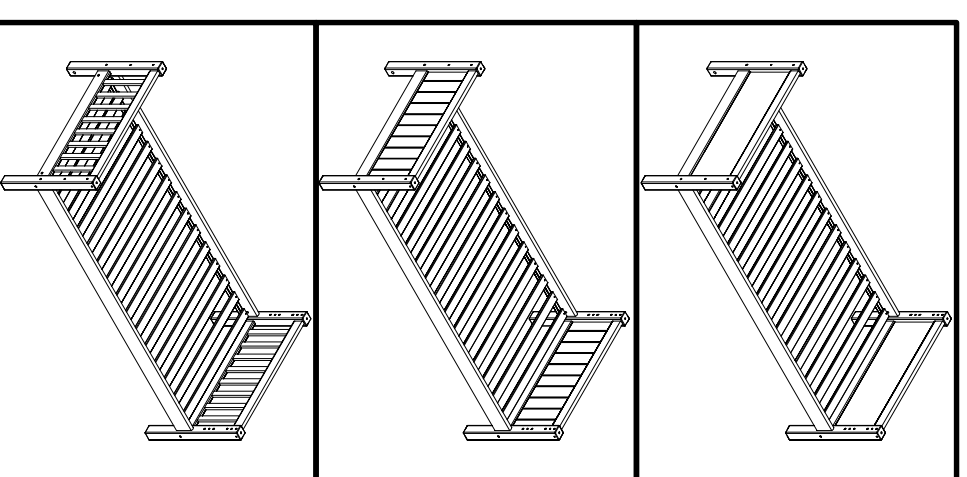

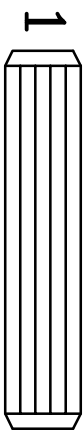

Z2 x8 pcs.

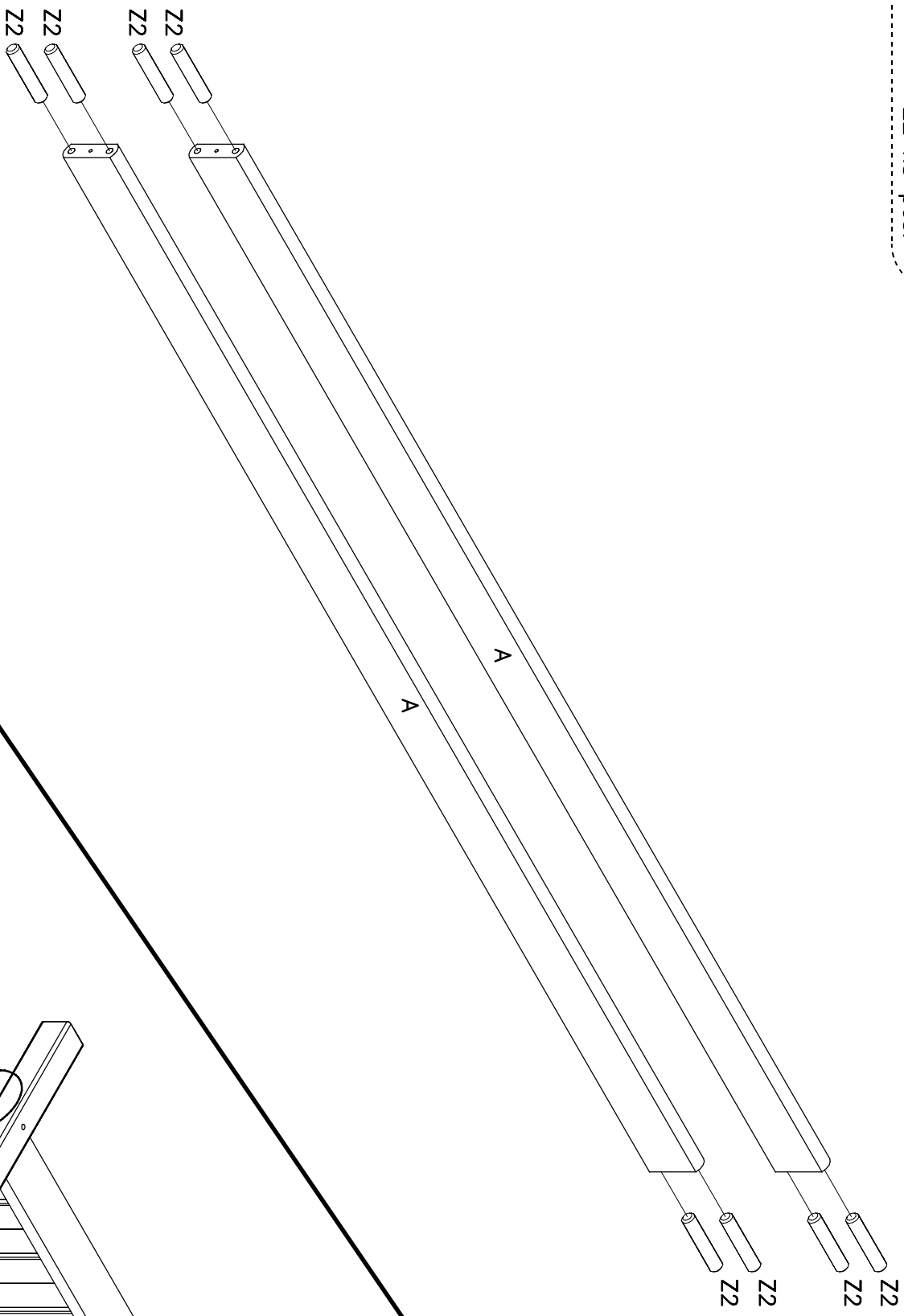

2

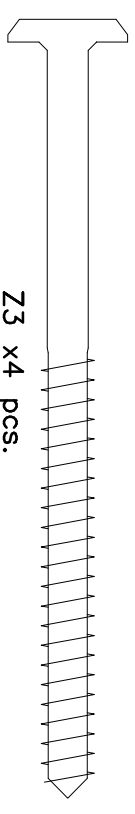

Z3 x4 pcs.

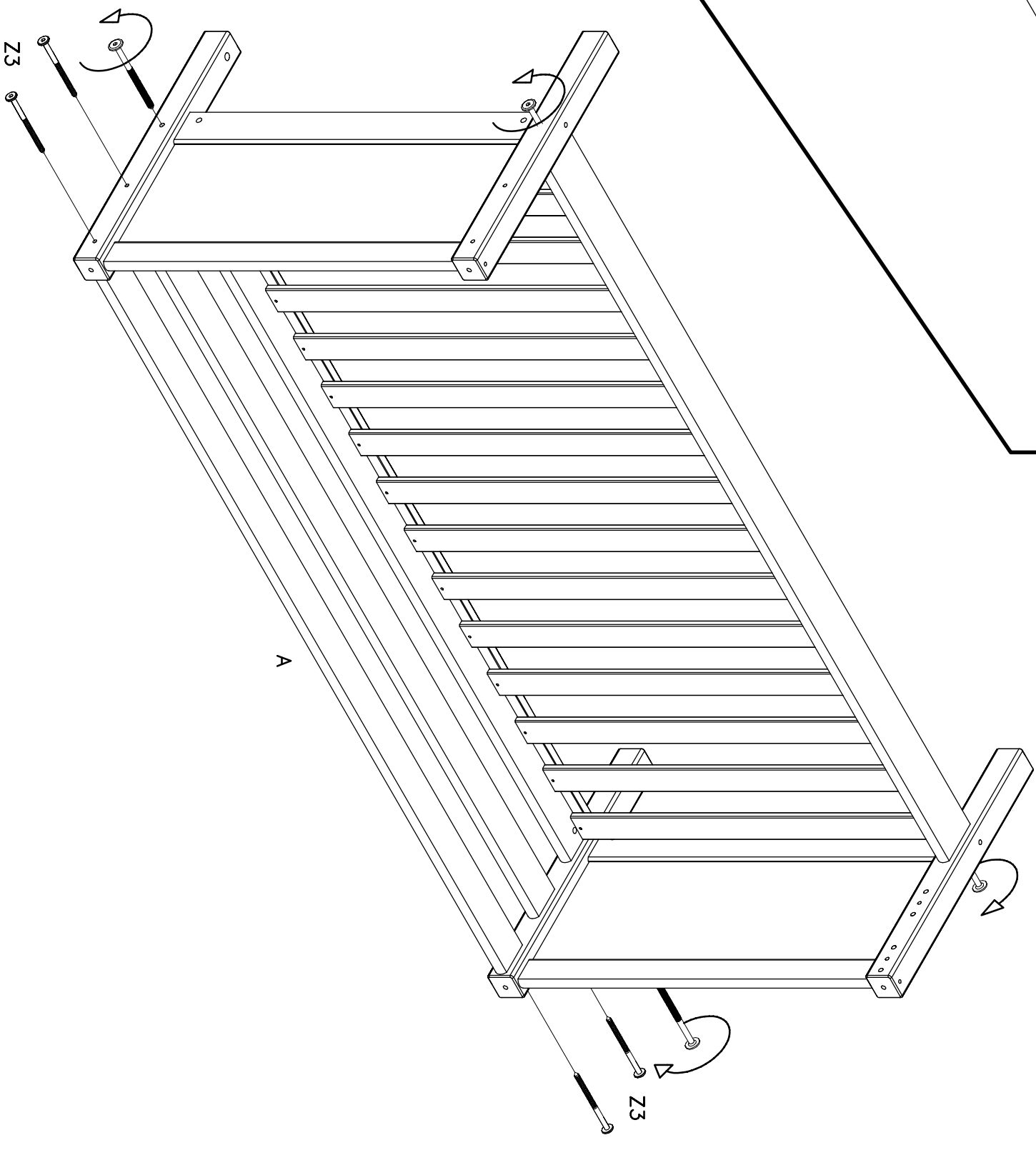

80-20602-40

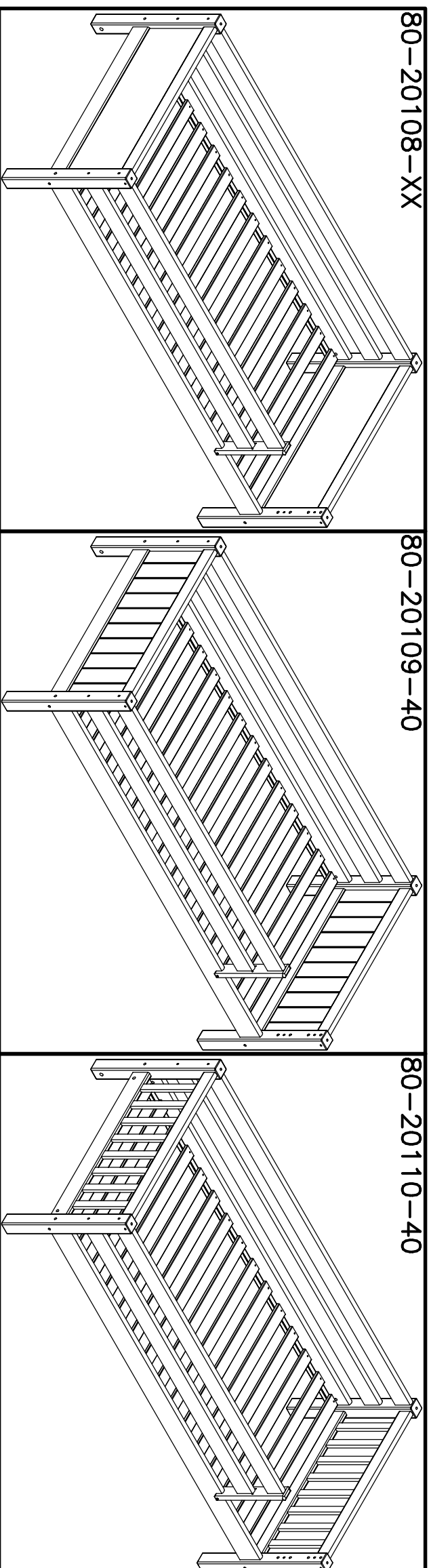

Before assembling this product, please ensure that all the components supplied comply with the list on this page. All Screw-type fittings can be tightened with this tool.



Avant de commencer l'assemblage, veuillez contrôler si tous les objets indiqués sont présents. Tous les vis peuvent être serrés par cet outil.

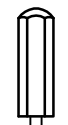

Bevor Sie mit dem Aufbau beginnen, kontrollieren Sie ob alle auf der Zeichnung angegebenen Teile vorhanden sind. Bitte verwenden Sie zur Montage einen Kreuzschraub-Ziher und den beiliegenden Innensechskantschlüssel.

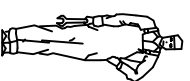

12-02615712-40

2 stck/pcs.

Ware-nr.
Part no.
Réf No

Stck.
Qty.
Qté.

Siehe Bild-nr.
See picture no.
Image no

Mass
Dim.
Dim.

12-02603611-40

1 stck/pcs.

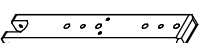

361x65x26

A

3930-10050 8 stck/pcs. 3909-70100

2 stck/pcs.

1571x89x26



Z2 $\varnothing 10 \times 50$ mm. Z3

3901-40030 2 stck/pcs. 3909-70060

$\varnothing 7 \times 100$ mm.

2 stck/pcs.



Z4 $\varnothing 4 \times 30$ mm.

Z15

$\varnothing 7 \times 60$ mm.

See assembly instruction in box no. 80-20101-40
 Voir notice de montage dans la caisse no. 80-20101-40
 Siehe Aufbauanleitung im karton no. 80-20101-40
 Zie voor de montage-instructie pakketnr. 80-20101-40

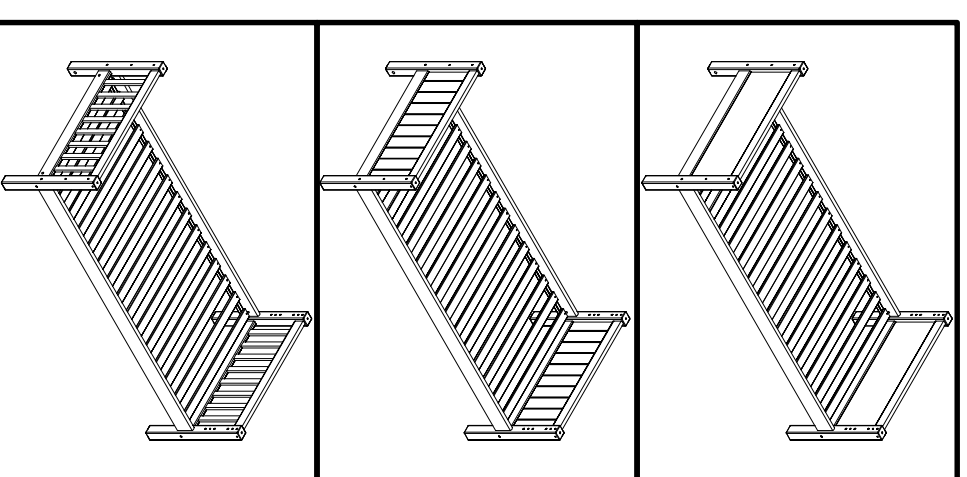

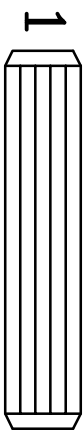

Z2 x8 pcs.



2

Z3 x2 pcs.

Z15 x2 pcs.

Z4 x2 pcs.

